

M2111

Cat Cafe Garden



NOTICE OF ASSEMBLE

Tips for assembling

1. Because this product contains small parts, children need to use this product with an adult to avoid accidental ingestion and cause suffocation hazard.
There are sharp objects in the product, be careful not to pierce people to avoid injury.
2. After all the materials are used in the required amount in the operation steps, put the remaining materials back into the original bag until the installation is completed.
(Avoid losing materials during the installation process)
3. The unit of dimension marked in the step diagram is "cm".
4. Tips for making template paper: Put the template on the back of the material, fix it with some small double-sided tape, and then cut out the material to prevent the cloth or template from moving in the cutting process, or causing errors in the cut material. Or lead to insufficient materials.
5. According to the "Parts Rule Example" at the bottom of this page, refer to the parts on the part number drawing, find the actual product and compare it with the bill of materials, and then install it after confirming that it is correct. (Wooden parts only)
6. It is not advisable to apply too much glue, so as not to wait for a longer time to dry, and overflow will affect the effect of the finished product.
7. There are unavoidable small deviations in the color of wood, fabric, and beads of different batches, without notice, thanks for understanding.

Tips for Assembling Wood



Find the corresponding block number, use a knife in the connection point gently press, you can take out the wood.

Use a knife to smooth out the burr.

Or use sandpaper to smooth out the burr

Testing on LED function

Be sure to test the LED lights before making the lighting, note that the LED white wire to the negative, gray wire to the positive reference to the following figure operation test.

1



DO NOT contact the LED wire end direct to the battery cell.

2

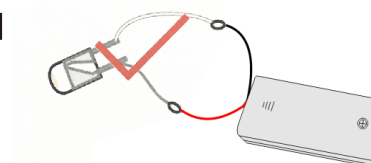

Use the provide battery holder. Make sue the correct polarity.

How to assemble the battery holder

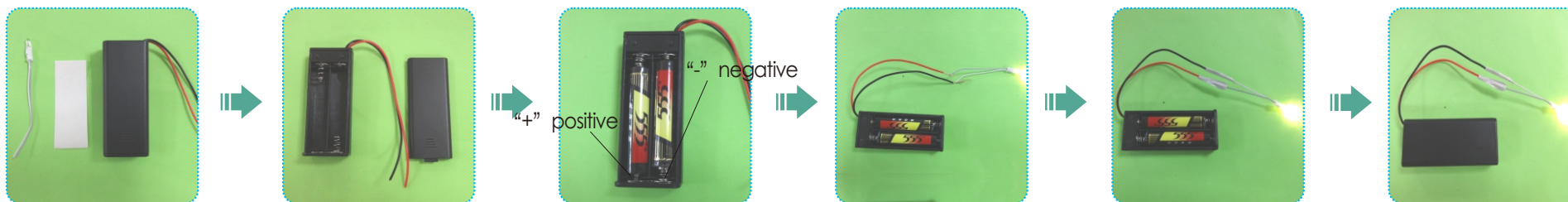

1. Material and tools needed:
- Battery holder, LED bulb, tape, screw driver and 2 pieces AAA size battery(not provided)

2. Use screw driver and take the lid off from the battery holder.

3. Insert the battery take notes on the polarity.

4. Connect the red wire to grey wire. Connect the black wire to white wire.

5. Wrap the exposed wire with the tapes.

6. Place the box lid and fastness with screw driver.

Examples of parts rule:

A01: The parts are directly in the box; B01: The parts are in the B bag; C01: The parts are in the C bag, and so on (Note: The printing paper is displayed in the step A13-01: The printing paper is placed directly in the box, The part number is A13-01. In the step, the template paper A14-F01 is displayed, A14 is the template paper, F01 is the cutting template used for the corresponding material, F01-01, F01-02 are the part numbers for the parts, and the printing paper and template paper are directly placed in the packaging box.)

Contents

Name	Materials Bags
Printing paper	A13、A14、A15 in Bag A (all of Printing paper and Template are in A13、A14、A15, total 5 pieces of A4 paper+2 pieces of A3+1 piece Transparent sticker)
European dining table	Bag B page 3
High stool&Menu	Bag B + Bag F + Printing paper page 3
Coffee cabinet& Tatami table	Bag B + Bag C + Bag G + Printing paper page 4
Coffee products	Bag C + Bag G + Bag H + Printing paper page 4-5
Dessert	Bag A+ Bag C + Bag F + Bag G + Printing paper page 5-6
Cat tower	Bag C + Bag F + Bag G + Printing paper page 6-8
Hanging box	Bag D + Bag F + Bag J page 8-9
Sofa&cushion	Bag C + Bag F + Printing paper page 10-11
Potted 1	Bag F + Bag G + Bag H + Printing paper page 11-12
Potted 2	Bag G + Bag H + Bag F + Printing paper page 12-13
Outdoor plants	Bag F + Bag H page 13-14
Light	Bag A + Bag C + Bag G + Bag J + Printing paper page 14
Awning&cathead	Bag A + Bag E + Bag G + Printing paper page 14-15
Roof	Bag A + Bag E page 15-16
Door&wall	Bag A + Bag D + Printing paper page 16-17
Outer frame	Bag A + Bag C + Bag D + Bag E + Bag G + Bag H + Printing paper page 17-21
Batteries box	Bag J page 22

Thumbnail of material list (reference only)



Thumbnail of printing paper & template paper (reference only)

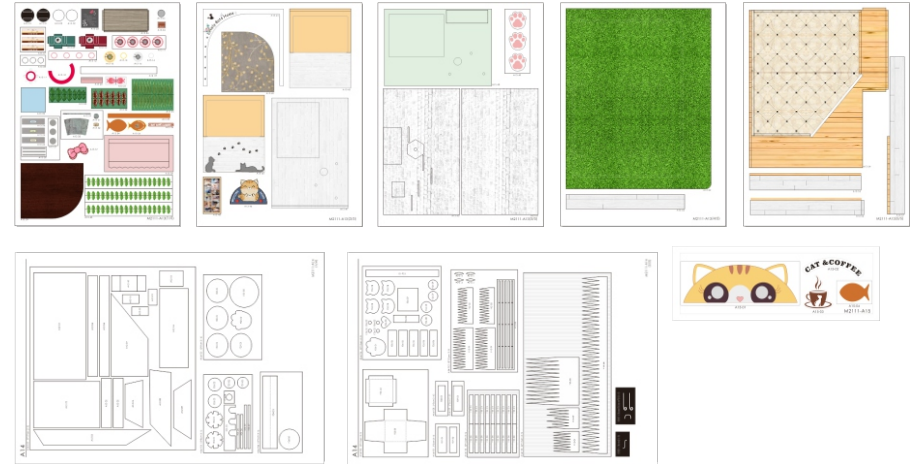

Welcome to the DIY world,
now follow me to start.

Symbol description used

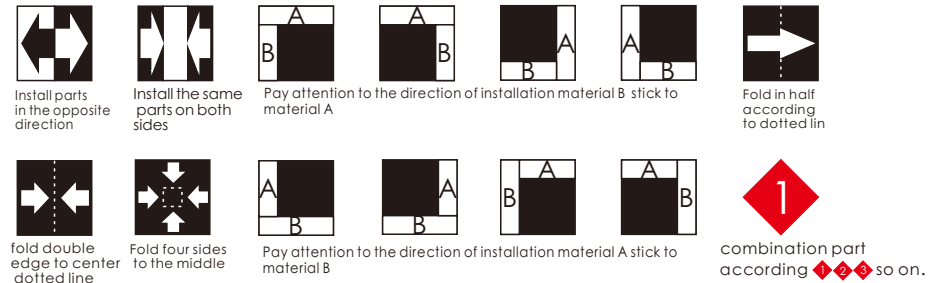

About the use of glue

Method for using glue:

1. After applying the glue, let it dry for a few seconds before pasting.
2. Fix it slightly with your hands, and finally put it aside to dry;

Tips:

When pasting the plane printing paper, a piece of waste bank card or telephone card can be used to wipe evenly after the glue is smeared on the wood board, and then the printing paper is pasted to squeeze out the air inside.

Types of glue:

White latex: Used for adhering soft materials, such as wood and paper.
 Alcoholic Glue: Used for adhering hard materials such as cloth, plastic, beads, wire, dust cover, etc.

*Tips for cutting template paper: put the whole template on the back of the material, fix it with some double-sided adhesive, and then cut out the material to avoid the cloth or template from moving in the cutting process, or the material cut out has errors or the material is insufficient.



European dining table

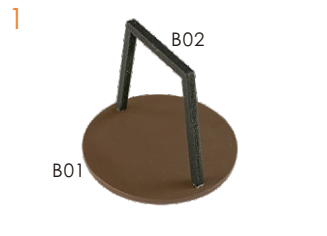
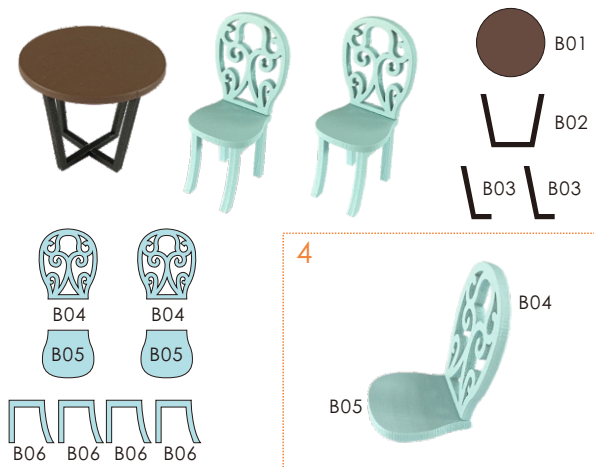

High stool & menu

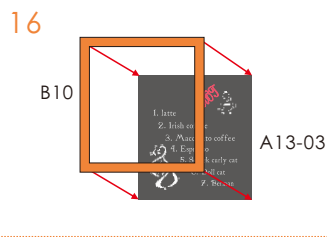
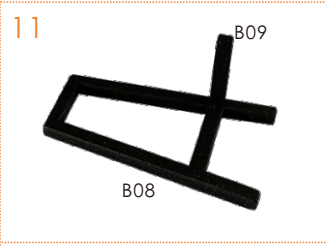
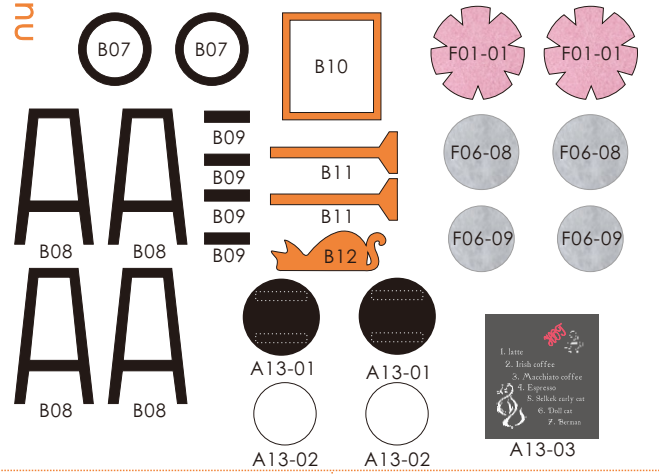
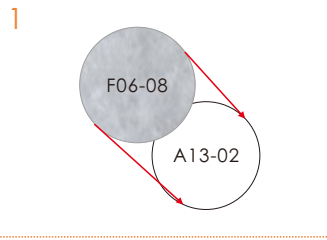

Coffee cabinet & Tatami table

Pick out C17-1 in C17 before making it

1
A13-04 (back side)
Fold with reference to dotted line

2
C17-1
A13-04
(underside)

3
(front)

4
B14
B13

4
B14

5
(underside)

6
G05
G04 G04

7
B16
B15

8
B17

9
B16

10
B17
Coffee bean rack

11
B18 B19 B19 B19
(bottom view)

12
(side view)

13
Make 2 pieces according to the previous steps

Coffee products

Please pull out C18-1, C18-2, C18-3, C18-5 in C18 before making

1
A13-05 (back side)
G15
(bottom view)

2
G06
(top view)

3
G10
1.3CM
Cut G10 out to 1.3CM

4
0.5CM
0.8CM
0.5CM
Bend according to G10 template as shown in the figure

5
G10

6
G10
0.8CM

7
G10
Cut out sharp corners at both ends as shown in the figure

8
G10

9
C18-2
Overlap the 3 pieces together

10

11
C18-3
C18-1
Fold together in the middle

12
G23
C18-2

13
G09
C18-2

14
G07



<p>1</p> <p>G02 1.3CM</p>	<p>2</p> <p>0.3CM G02 0.3CM</p> <p>Bend according to G02 template as shown in the figure</p>	<p>3</p> <p>G02</p>	<p>4</p> <p>G04 C18-5</p>	<p>5</p> <p>G16</p>	<p>6</p> <p>H19 0.8 CM*3 pieces</p> <p>Cut H19 into 3 pieces of 0.8 CM</p>
<p>7</p> <p>H19 A13-08</p>	<p>8</p> <p>A13-07 A13-07 A13-07</p> <p>Make 3 pieces according to the previous steps</p>	<p>9</p> <p>G16</p> <p>Fill one of the can with G16</p>	<p>10</p> <p>G14 G14</p> <p>Put the right amount of G16 in the other two cans and cover with G14</p>	<p>11</p> <p>A13-09</p> <p>Fold with reference to dotted line</p>	<p>12</p>
<p>13</p>	<p>14</p>	<p>15</p>	<p>16</p> <p>A13-10</p> <p>Make A13-10 in the same way.</p>	<p>17</p> <p>Put coffee bean product as shown in the picture</p>	

Dessert

Please pull out C18-4 in C18 before making.
Please cut out A12-A, F06, F07, F08, F09 by template paper
A14-A12-A, A14-F06, A14-F07, A14-F08, A14-F09.

C18-4	C18-4	F06-05	F07-01	F08	F17
		F06-05	F07-02		
A12-A-10	A12-A-08	F06-05	F08-01	F18	G19
		F06-06	F09-01	G01	G22
A12-A-09	A12-A-08	F06-06		G02	G17 G17 G17
		F06-06			G22
A13-06	A13-13	A13-14	A13-15	A13-16	A13-11
					A13-12

<p>1</p> <p>A13-11</p> <p>Cut out the grey part of A13-11 as shown in the figure</p>	<p>2</p>	<p>2</p> <p>A13-12</p>	<p>3</p> <p>A13-13 A13-15</p> <p>Make the rest of the plate in the same way</p>
<p>4</p> <p>1.2CM 1.2CM A12-A-10</p> <p>Use a knife at the 1.2CM at both ends of the PVC Pull it gently and be careful not to cut it off.</p>	<p>5</p> <p>A12-A-10</p> <p>Bend as shown in the picture</p>	<p>6</p> <p>C18-4 A12-A-08</p> <p>Pay attention to the direction of C18-4 paste</p>	<p>7</p> <p>C18-4 A12-A-08</p> <p>Pay attention to the direction of C18-4 paste</p>
<p>8</p> <p>A12-A-10</p> <p>Note the pasting direction</p>	<p>9</p> <p>A12-A-09</p>	<p>10</p> <p>A12-A-09</p> <p>Stick A12-A-09 in the middle.</p>	<p>11</p> <p>F06-05 F09-01 F06-05 F07-01</p> <p>Overlay F06-05, F07-01, F09-01 in image order</p>

<p>12</p> <p>To create a triangular shape</p>	<p>13</p> <p>Cut out three triangles</p>	<p>14</p> <p>Take a small amount of F08 and cut it into pieces</p>	<p>15</p>	<p>16</p>	<p>17</p> <p>Place the cake on a red plate, just one</p>
<p>18</p> <p>Overlay F06-06, F07-02, F08-01 in image order</p>	<p>19</p>	<p>20</p>	<p>21</p> <p>Place the sandwich on a red plate, just one</p>	<p>22</p> <p>Take 4 pieces of F18 (color can be random) paste as shown</p>	<p>23</p>
<p>24</p> <p>Display food like this</p>	<p>25</p>	<p>26</p>	<p>27</p> <p>Take 3 pieces of F18 (color can be random) pasted as shown</p>	<p>28</p>	<p>29</p> <p>Cut F-17 into three pieces</p>
<p>30</p>	<p>31</p>	<p>32</p>	<p>33</p>	<p>34</p>	<p>35</p> <p>Cat's paw cake</p> <p>Food is laid out on the Tatami table as shown</p>
<p>36</p> <p>Sandwiches</p> <p>Food is laid out on another tatami table as shown</p>	<p>38</p> <p>Pastries Coffee beans</p>	<p>Cattower</p> <p>Please pull out C17-3, C17-4 in C17 before making.</p> <p>Please press A14-F01 template paper cut out F01-04 before making F01 (cutting way can refer to the following steps)</p>			<p>1</p>
<p>37</p> <p>Dessert rack</p>			<p>2</p>		<p>3</p>

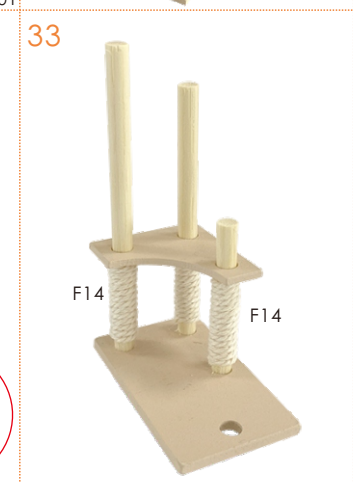
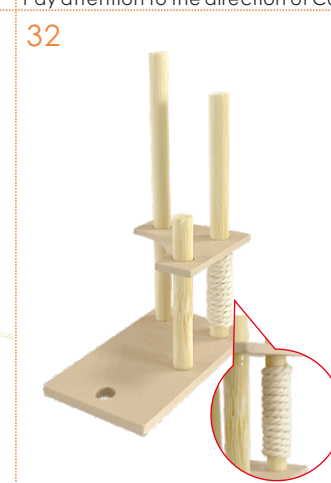
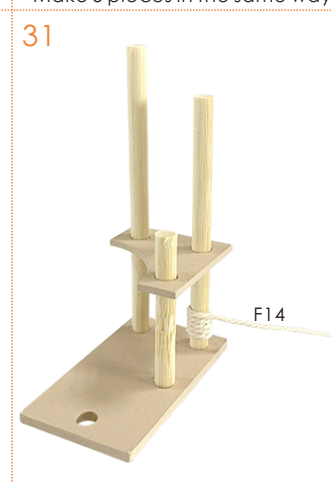
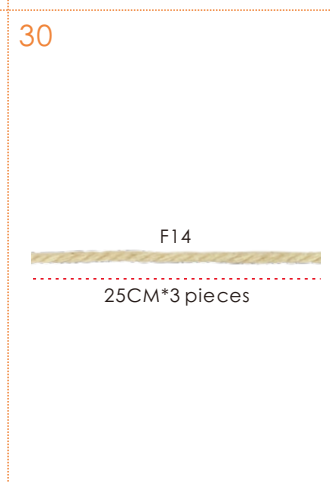
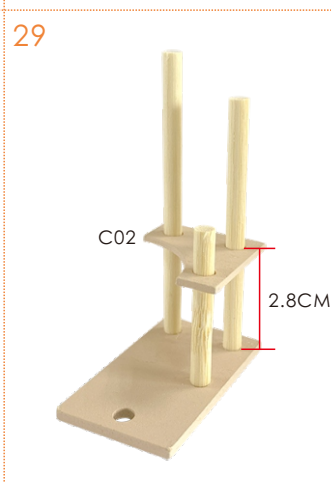
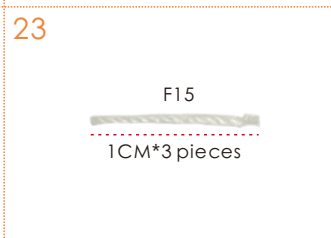
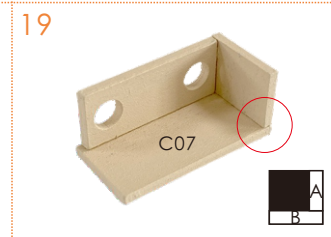
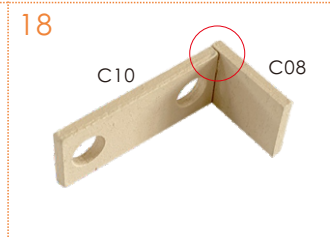
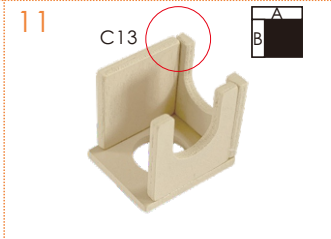
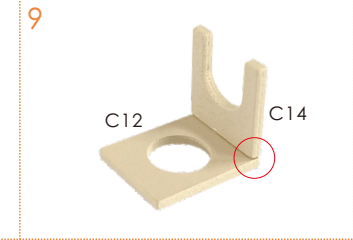
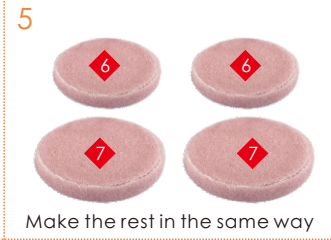

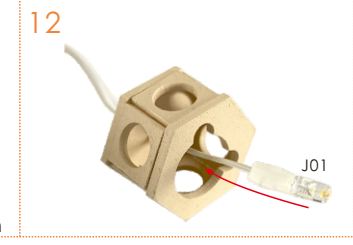
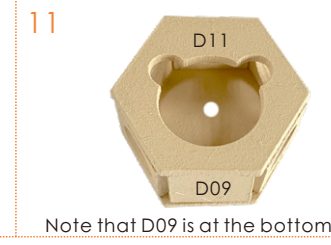
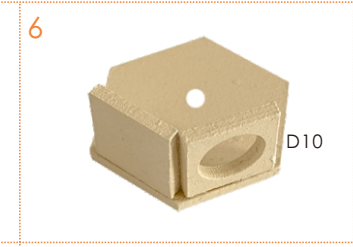
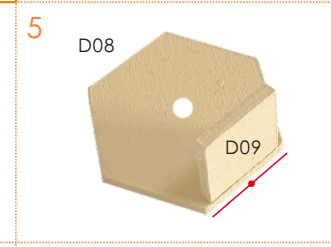
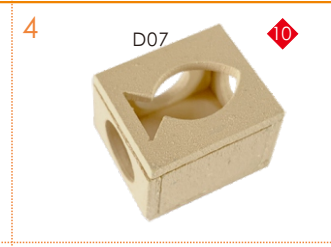
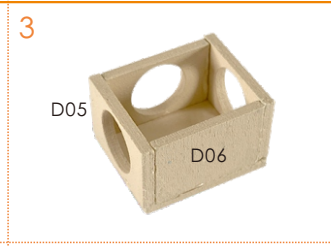
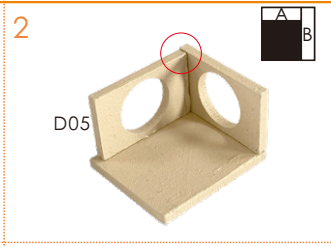
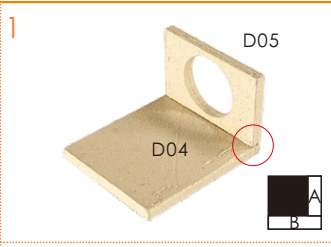
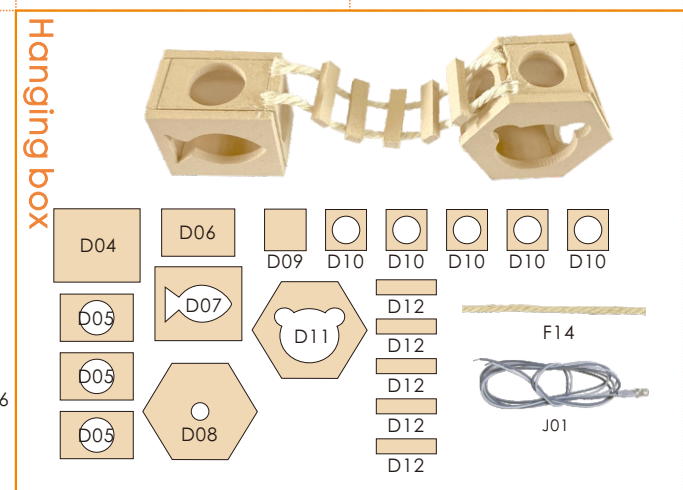
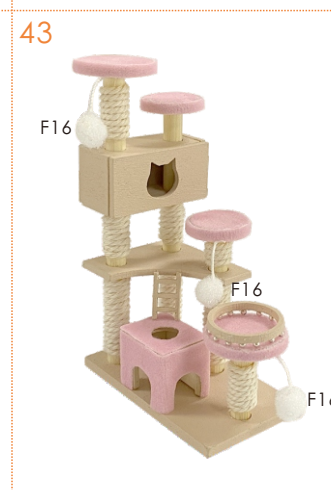
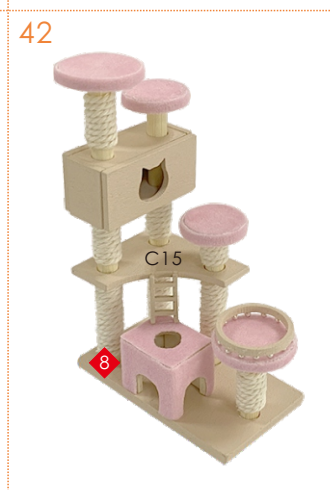
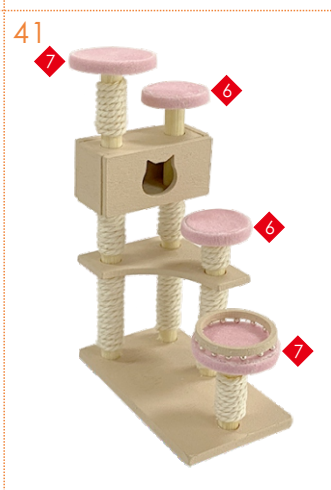
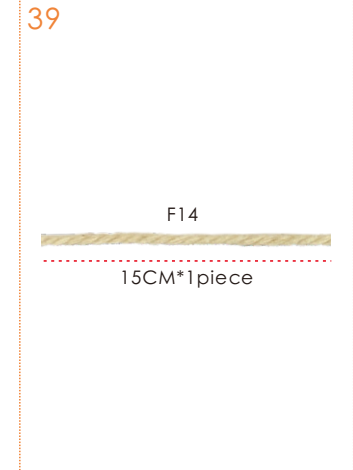
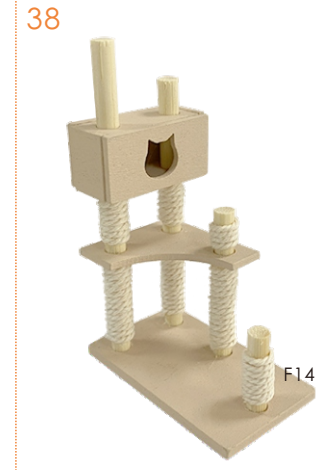
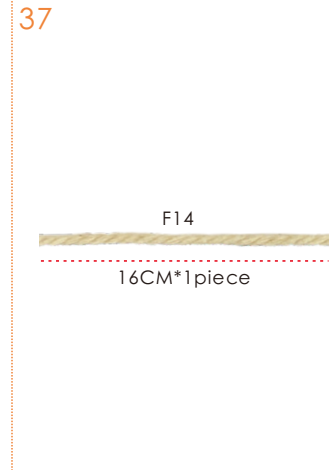
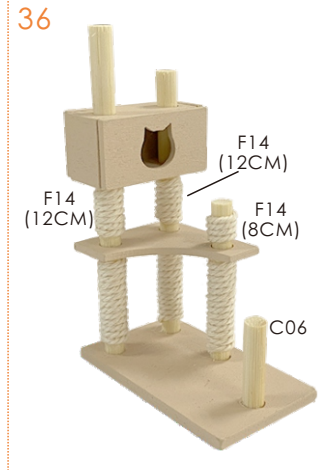
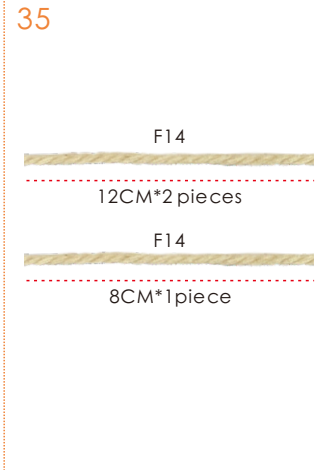
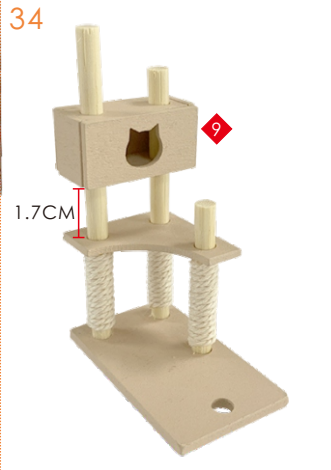

Note that D09 is at the bottom



<p>13</p> <p>J01</p>	<p>14</p> <p>F14 5CM*2 piece</p>	<p>15</p> <p>0.7CM D12 D12 0.7CM</p>	<p>16</p> <p>0.5CM D12 D12 D12</p> <p>Each one about 0.5 CM apart</p>	<p>17</p> <p>10</p>	<p>18</p> <p>11</p>
----------------------	--------------------------------------	--	---	---------------------	---------------------

Cat Tools

Please pull out C17-5 in C17 before making.
Please cut out F04, F06 according to template paper A14-F04, A14-F06 before making.

C17-5 G02 G08 G13 F16
G03 F15
F10 H02 A13-17 A13-18
A13-19
A13-20 A13-21
F04-01 F04-02
F06-10

<p>1</p> <p>A13-17</p> <p>Fold the white part down as shown</p>	<p>2</p> <p>A13-18</p>	<p>3</p> <p>(front)</p>	<p>4</p> <p>(underside)</p>
<p>5</p>	<p>6</p> <p>F10</p> <p>Cut a small amount of F10 into small particles</p>	<p>7</p> <p>F10</p>	





<p>8</p> <p>F06-10 A13-19</p>	<p>9</p>	<p>10</p> <p>F04-01 (back side) A13-19</p> <p>Cover F06-10, A13-19 with F04-01</p>
-----------------------------------	----------	--

<p>11</p> <p>12</p> <p>F04-02 C17-5</p>	<p>13</p>	<p>14</p> <p>Wrap it around 12</p>	<p>15</p> <p>A13-20</p> <p>Cut out A13-20 and roll up as shown</p>
---	-----------	------------------------------------	--

<p>16</p> <p>G08</p>	<p>17</p> <p>G03 4CM</p>	<p>18</p> <p>F15 1.5CM</p>	<p>19</p> <p>G03 F15 0.5CM</p>	<p>20</p>	<p>21</p>
----------------------	------------------------------	--------------------------------	--------------------------------	-----------	-----------

<p>22</p>	<p>23</p>	<p>24</p>	<p>25</p>	<p>26</p>	<p>27</p>				
<p>28</p>	<p>29</p>	<p>30</p> <p>Fold A13-21 in half and cut a small opening</p>	<p>31</p> <p>Put F15 through the opening and glue it</p>	<p>32</p> <p>Cut out the little fish</p>	<p>33</p>				
<p>Sofa & Cushion</p> <p>Please pull out C16-1, C16-2, C17-6, C17-7 in C16 and C17 before making.</p> <p>Please cut F02, F05, F06 according to template paper A14-F02, A14-F05, A14-F06 before making. (note the direction of F02-02 when cutting)</p>						<p>1</p>	<p>2</p>	<p>3</p>	<p>4</p>
<p>5</p>	<p>6</p>	<p>7</p> <p>(front)</p>	<p>8</p>	<p>9</p> <p>(underside)</p>	<p>10</p> <p>(above)</p>				
<p>11</p> <p>Insert an appropriate amount of F19 and flatten it</p>	<p>12</p> <p>(underside)</p>	<p>13</p> <p>(front view)</p>	<p>14</p>	<p>15</p> <p>(underside)</p>	<p>16</p> <p>(front)</p>				
<p>17</p>	<p>18</p> <p>Paste as shown (note the direction of the cat's paw)</p>	<p>19</p>	<p>20</p>	<p>21</p>	<p>22</p>				

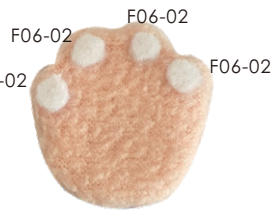

19 	20 	21 	22 	23 	24 
25 	26 	27 	28 	29 	30 
31 	32 	33 	34 	35 	36 

Potted 1



G11 H11

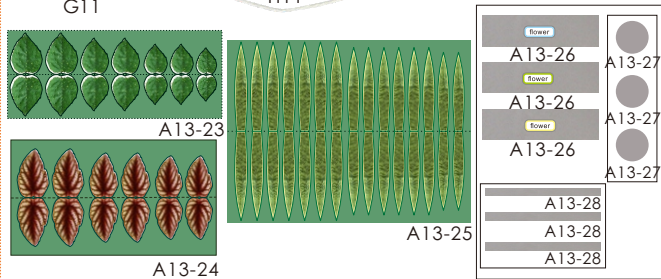

F10

9

10

1

2

3

4

5

6

7

8

9

10

11

12

13

14



15

A13-24

Fold A13-24 symmetrically and cut out each leaf

16

G11

2.5CM*2 pieces

2CM*2 pieces

1.7CM*2 pieces

17

0.3CM

Bend each one as shown

18

G11

2CM*1 piece

Cut out a G11 to bind it

19

20

A13-24

A13-26

F10

21

A13-25

Fold A13-25 symmetrically then cut each leaf out and gently bend it in a small curve

22

A13-25

A13-26

flower

23

A13-25

flower

24

H11

H11

2.2CM

2CM

25

H11

H11

F10

26

H11

flower

Potted 2

Please cut out F11 and F12 according to template paper A14-F11 and A14-F12 before making

1

A13-30(back side)

A13-31

2

3

A13-29

4

A13-32

5

H13

H14

6

H13

7

H14

Cut the area below the red line

8

10

H12

11

H14

Cut out the area below the red line and save the lower half

12

13

H13

14

H14

Cut out the leaves of the lower half of the crop

15

16

H07

H07

H07

H07

1CM

Leave the roots 1 cm long

17

H07

G21

18

H14

19

H03

H03

G01

20

dessert

G01

21

F11-01

4CM

0.5CM

22  0.5CM

23  F12-03

24 

25 

26 
Make 12 pieces flowers in the same way
Only 2 flowers are needed here
Leave the rest for later use

27 
G11
2CM
1.7CM

28  G11 G11

29  F12-04 F12-04 F12-04

30  G20

Outdoor plants



Please cut out F12, F13 according to A14-F12, A14-F13 before making

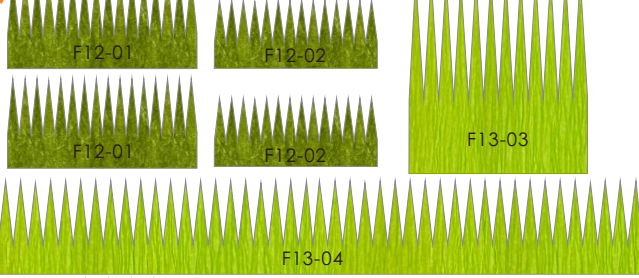

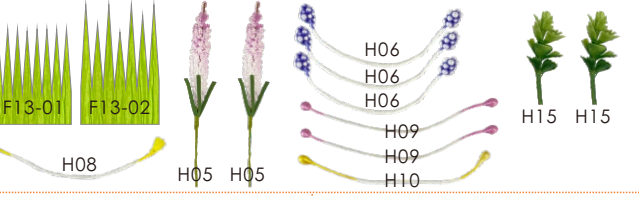

F12-01 F12-02 F13-03 F13-04





F13-01 F13-02 H05 H06 H08 H09 H10 H15 H15

1  F12-01

2  F12-01 2.3CM

3  H09 H09
Take a pair of H09 and cut them in half

4  H09 F12-01 **15**

5  F12-02 1.5CM

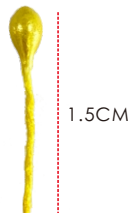
6  H10 1.5CM

7  H10 F12-02 **16**

8  F12-01 F12-02
Make the other F12-01, F12-02

9  H08 H08 1.5CM

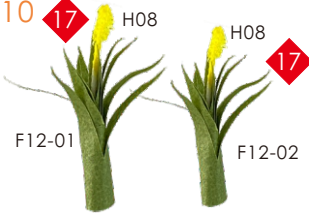
10  H08 H08 **17**

11  F13-01

12  H09 H09 2.5CM

13  H09 F13-01 **18**

14  F13-02 **19**

15  F13-03 **20**

16  F13-04 3.3CM

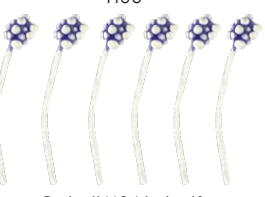
17  H06
Cut all H06 in half

18  H06 F13-04 **21**
Insert H06 as shown

<p>19</p> <p>H05</p>	<p>20</p> <p>6.7CM</p>	<p>21</p> <p>H05</p>	<p>22</p> <p>6CM</p>	<p>23</p> <p>H15</p>	<p>25</p>
<p>24</p>	<p>26</p>				
<p>Light</p> <p>Please pull out C17-02 in C17 before making. Please cut out A12-B by template paper at A12-B before making.</p> <p>A15-04</p> <p>A12-B-14</p> <p>C17-02 J01 G18 A13-33</p> <p>A13-34 A13-35 A15-04 A12-B-14</p>	<p>1</p> <p>A15-04</p> <p>A12-B-14</p>	<p>2</p> <p>A15-04</p> <p>Glue them together and cut out the shape of the fish</p>	<p>3</p> <p>A13-35</p> <p>A15-04</p> <p>Put A13-35 in the middle</p>	<p>Awning & Cathead</p> <p>A13-38</p> <p>A15-01 A13-36 A13-37 F03 A12-B-13</p> <p>Please cut out A12-B by template paper A14-A12-B before making</p>	
<p>7</p>	<p>8</p> <p>Drill a small round hole</p>	<p>9</p> <p>J01</p>	<p>10</p> <p>(front side)</p> <p>26</p> <p>Cover up</p>	<p>1</p> <p>A13-38</p> <p>F03</p>	<p>2</p> <p>Cut from the inside of A13-38</p>
<p>11</p> <p>(back side)</p>	<p>12</p> <p>G18</p> <p>J01</p>	<p>13</p>		<p>3</p> <p>Fold A13-38 with reference to dotted line</p>	<p>4</p> <p>E03</p>

5  A13-36

6  G10
3.5CM*2 pieces

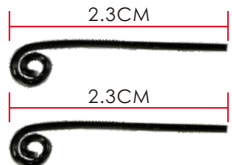
7  2.3CM
2.3CM
Bend it according to template paper G10, make 2 pieces

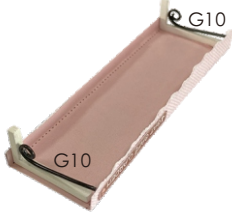
8  G10

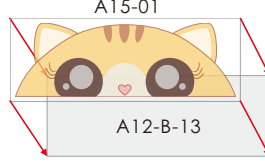
9  A15-01
A12-B-13

10  Cut down the cat shape sticker

11  E17

12 

13  A13-37

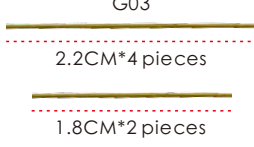
14  G03
2.2CM*4 pieces
1.8CM*2 pieces

15  2.2CM
G03 1.8CM

16  G03

Roof

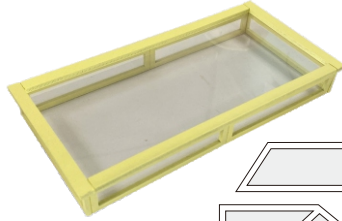
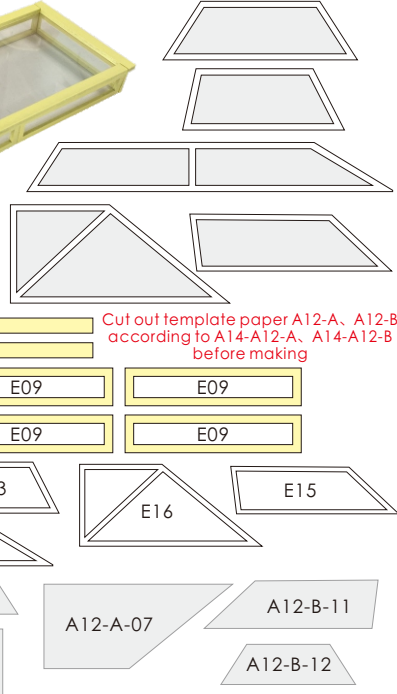
E07
E07

E08
E08

E09 E09 E09
E09 E09 E09

E12 E13 E15
E14 E16

A12-A-01
A12-A-03
A12-A-04
A12-A-04
A12-A-05 A12-A-05
A12-A-06

A12-A-07
A12-B-11
A12-B-12

Cut out template paper A12-A, A12-B according to A14-A12-A, A14-A12-B before making

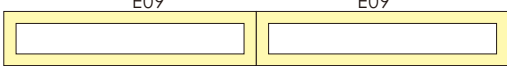
1  E09 E09

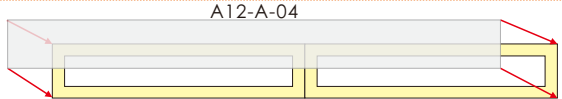
2  A12-A-04

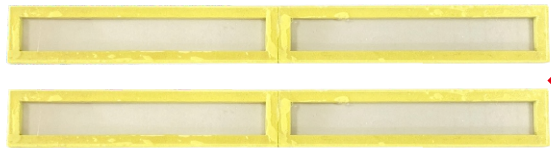
3  27

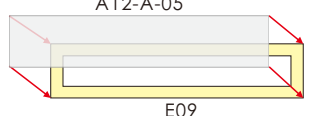
4  A12-A-05
E09

5  28
Make 2 pieces according to the previous steps

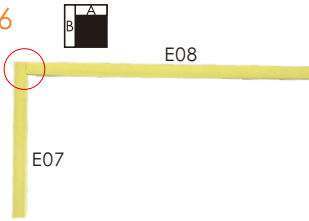
6  E08
E07

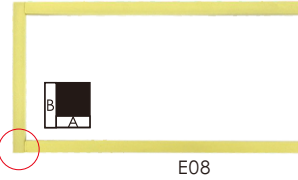
7  E08

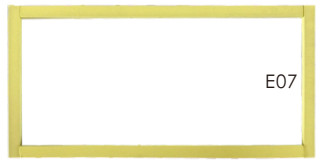
8  E07

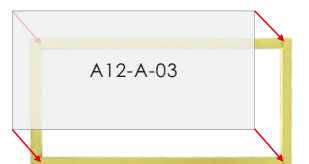
9  A12-A-03

10  29

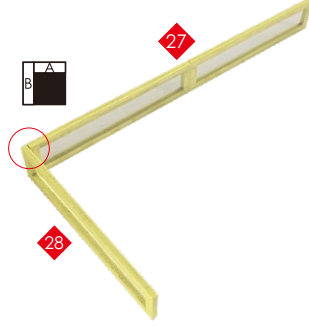
11  27

The PVC side facing inward

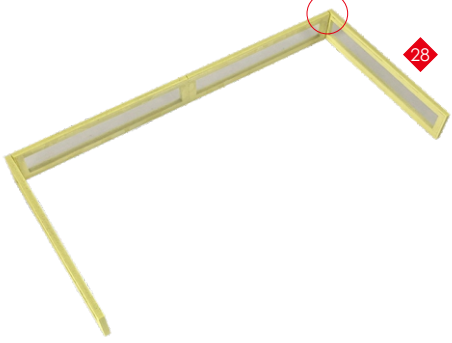
12  28

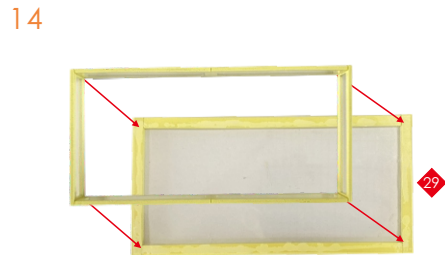

The PVC side facing inward



(Inward view)



(Top view)

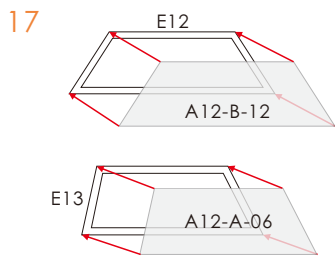

Paste all as below(Pay attention to the paste direction)

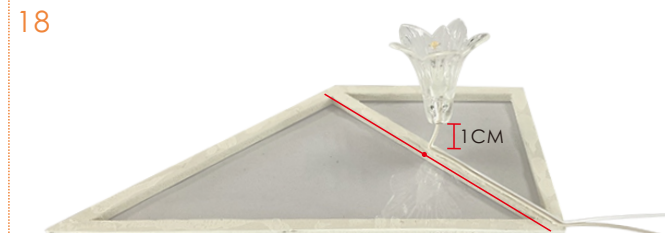
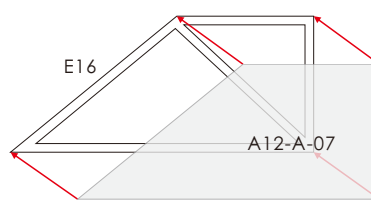
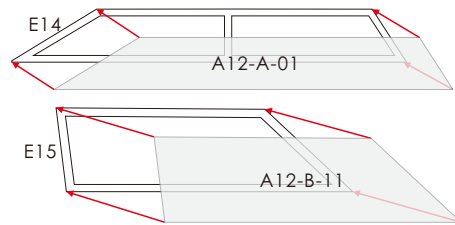

Paste the light on the middle of E16(Paste on the PVC side)

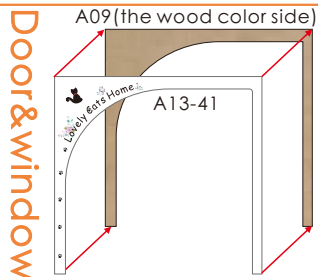

Door&window



Cut down template paper A12-A-02

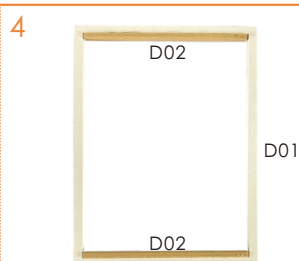

(Front side)

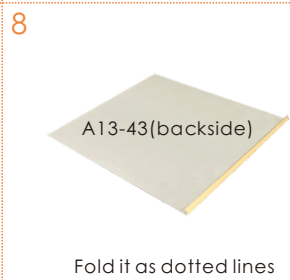

Fold it as dotted lines

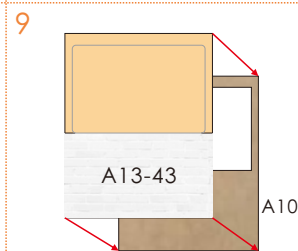

Cut down as picture



Paste A13-44 in the other side



Paste it as picture

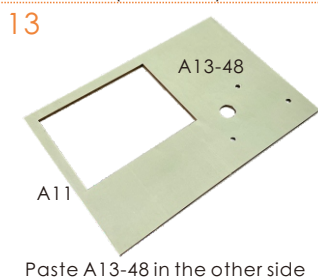

Paste A13-48 in the other side

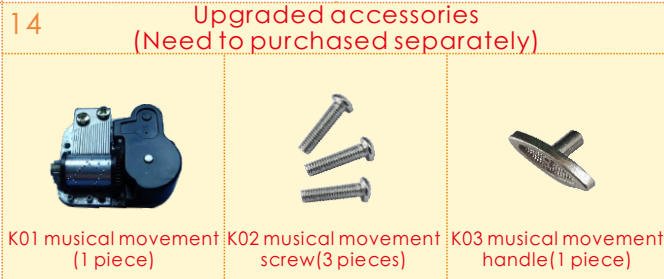

Upgraded accessories
(Need to purchased separately)

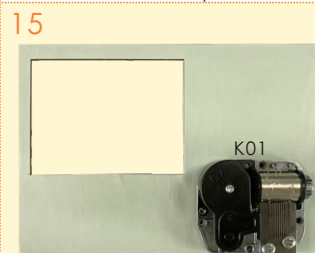

K01

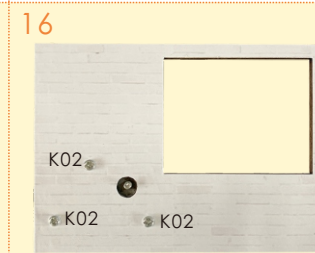

K02

K02



K03

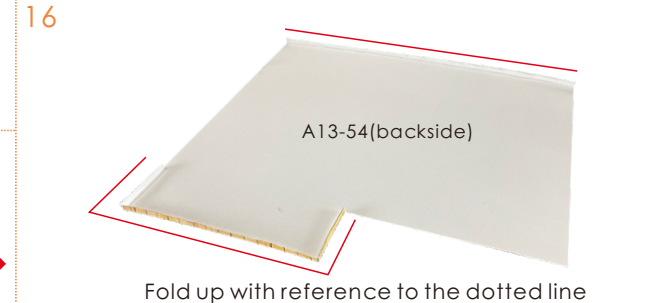
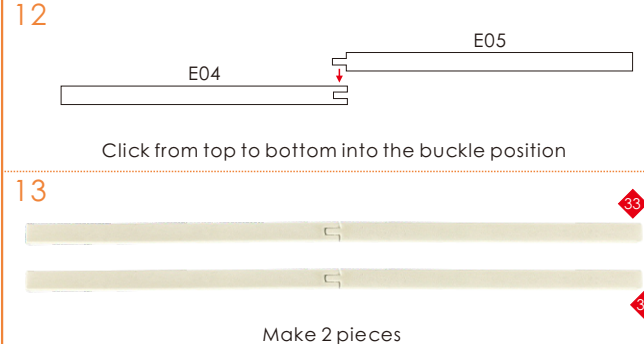
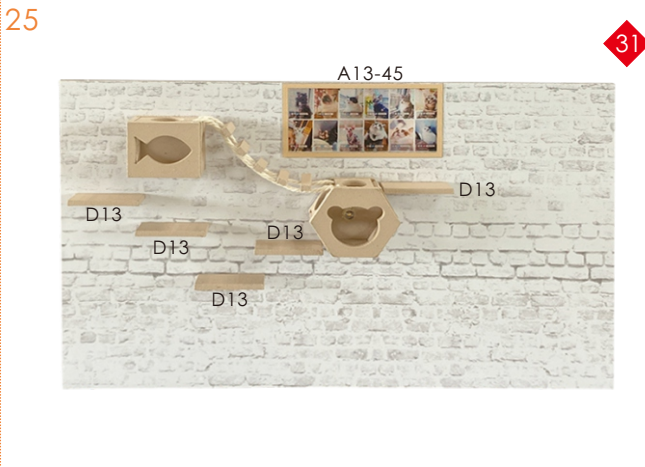
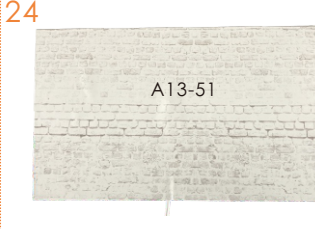
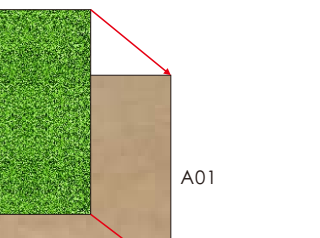
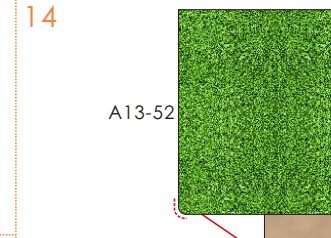
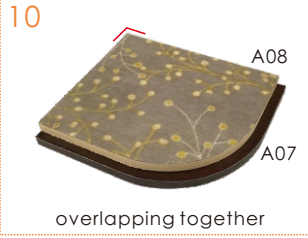
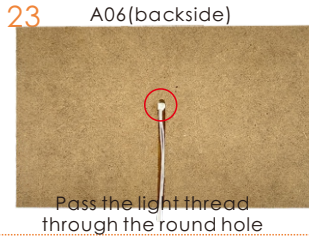
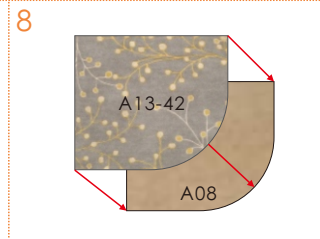
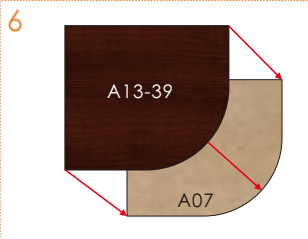
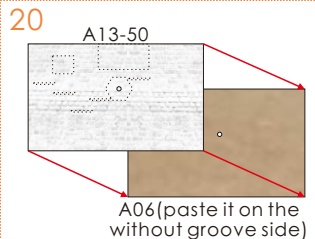
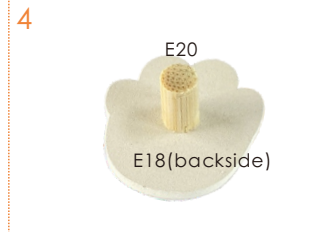
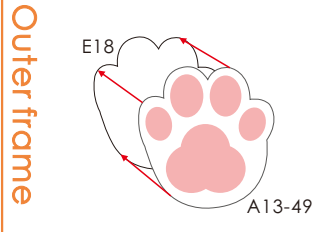
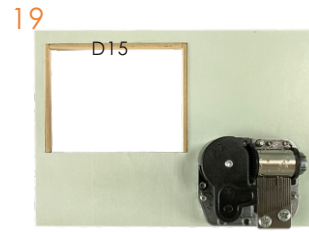
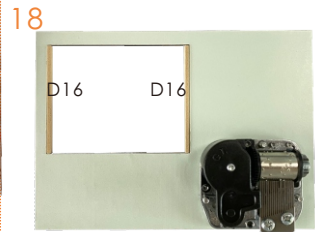





37

38

39

40

41

42

43

44

45

46

47

48

49

50

51

52

53

54

coffee cabinet

coffee bean cabinet

plants

catfood

sofa

D18

A10

E02

E02

E02

H01

H03

flower

dessert

plant (tall)

high stools

Pass 33 on the A06, as photo vertical

E06

E06

A13-46

roof

E10

E10

E11 E11 E11 E11 E11 E11

Each interval is about 0.9CM

E12 E13

Tilt and fix E12 and E13 at the same height (The PVC side facing inward)

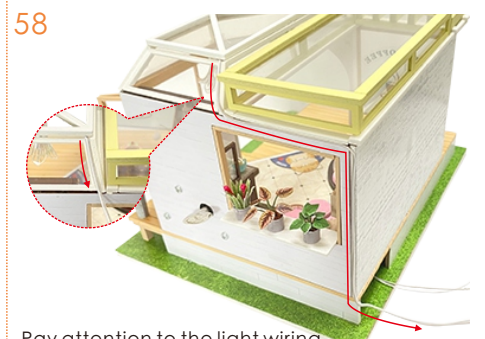

Pay attention to the light wiring



Make G11 through the roof truss as photo



Make others as photo

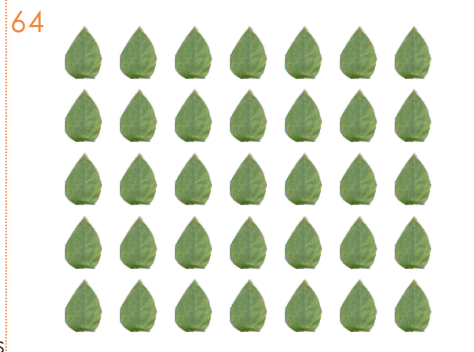
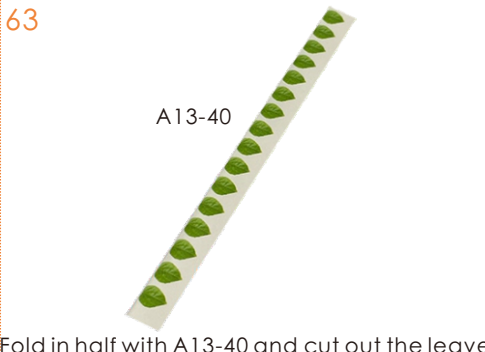

Fold in half with A13-40 and cut out the leaves

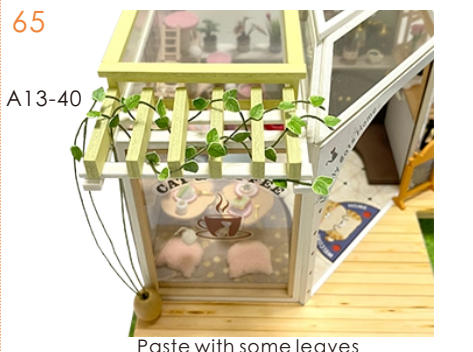

Paste with some leaves



Paste with flower



signboard



Pay attention to the light wiring



Decor with chairs and table



How to assemble the battery holder

Statement:
the lamp wires cannot be inserted into the output socket.

- - Can use 2*AAA batteries
- - Please notice the place of anode and cathode when pit in the batteries
- - Rechargeable batteries are not blunt electricity
- - Rechargeable batteries can only be charged under adult supervision
- - Rechargeable batteries should be removed from the toy before charging
- - Different types of batteries cannot mix;
- - Do not mix new batteries in use with semi-used batteries.
- - Run out of battery should be removed from the toy
- - The power shall not be short circuit

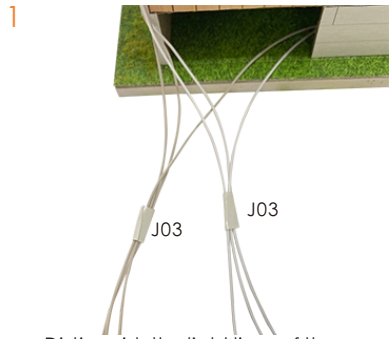

Distinguish the light lines of the same color.

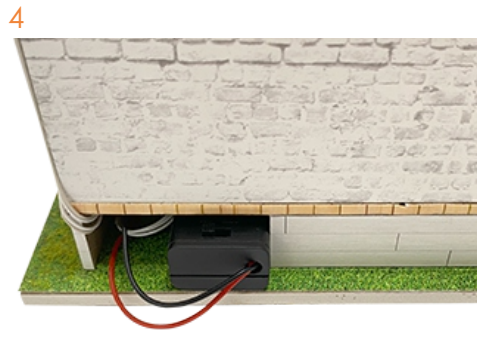

cut all the LED light wires to the same length
peel off the film of the LED light wires and then
wrap it together in the same color.

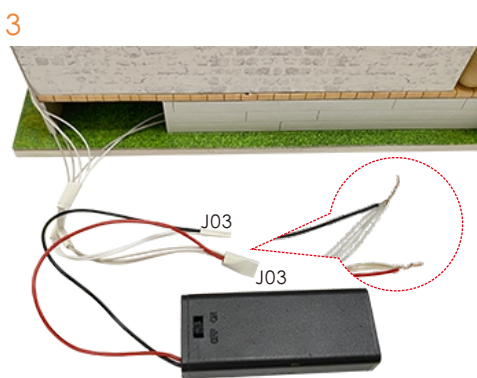

Put all gray wires with battery box red wires together,
and put all white wires with battery box black
wire together.
Wrap the bare wires with adhesive tape J03.
Make sure the LED lights are on.



With dust cover at night



Installation of dust cover

dust cover
(Upgrade version accessories need to be purchased separately)



scale:1:10
Z01 plexiglass(transparent)
23.5*17.5*0.18(2pieces)



scale:1:10
Z02 plexiglass(transparent)
18.64*17.5*0.18(2pieces)

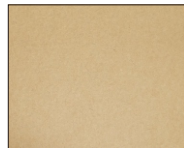

scale:1:13
Z03 plexiglass(transparent)
23.5*19*0.18(1piece)

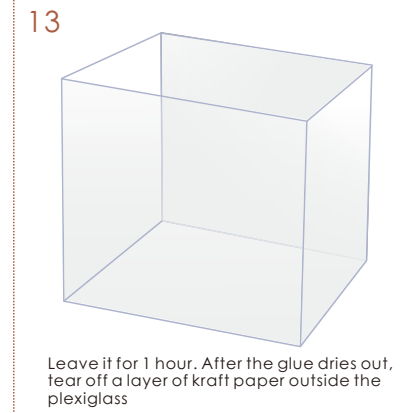
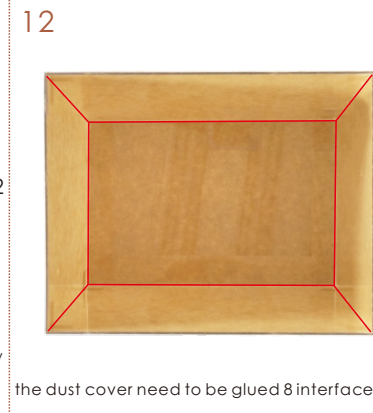
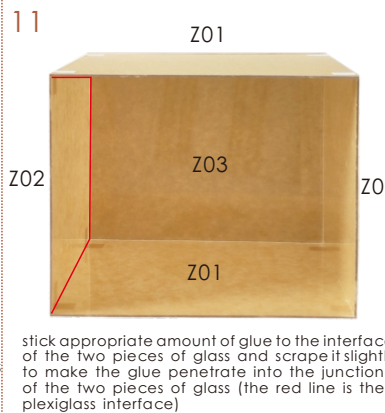
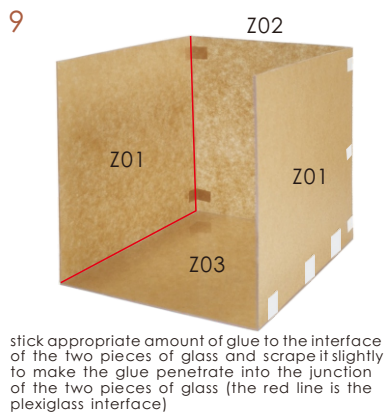
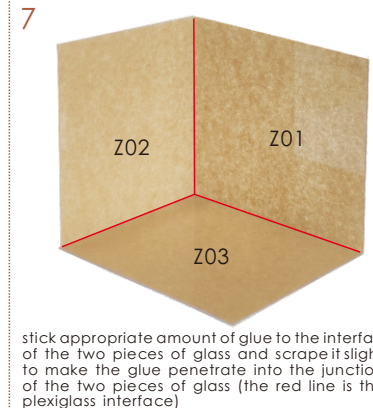
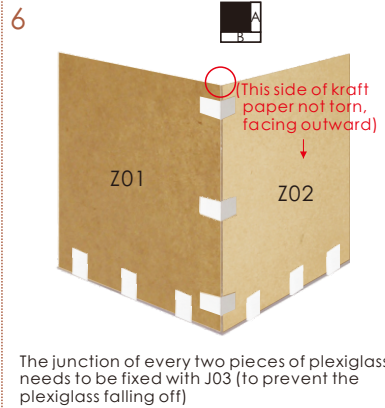
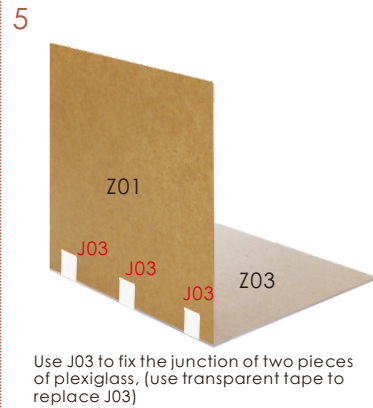
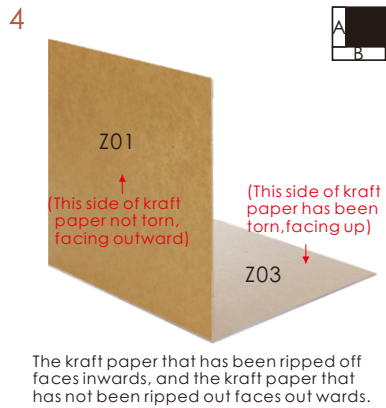
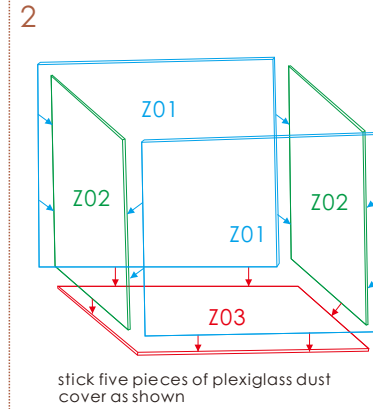
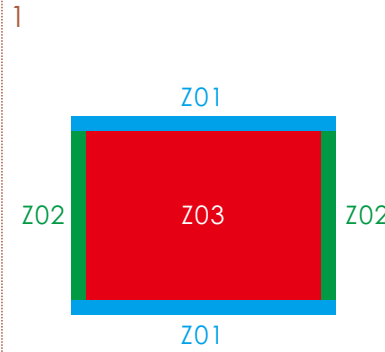

The instruction manual should be keep, after assembled.